

STEPPERONLINE®

User Manual

LA8 Series Linear Actuators



©2025 All Rights Reserved

Address: 15-4, #799 Hushan Road, Jiangning, Nanjing, China

Tel: 0086-2587156578

Web: www.omc-stepperonline.com

Sales: sales@stepperonline.com

Support: technical@stepperonline.com

LA8 Series

Model Explanation

LA8 - 24 L L10 (S) 3 - 500

Stroke Length:500mm

No. of Sensors

Motor installation standard (no letter means stepper motor)

S: Standard servo

P: Panasonic servo

Lead:10mm

Otor Mounting Position:

U:Upper

B:Under Fold

L:Left Fold

R:Right Fold

Motor Mounting Flange:

24:Nema 24 Stepper

60:60mm Servo

Series

Specifications

Nema 24 Stepper drive:

Position accuracy (mm)		0.04	
Ball screw lead (mm)		48	
Maximum speed (mm/s)		400	800
Maximum payload (kg)	Horizontal	25	20
	Vertical	-	-
Rated thrust (N)		61	

Note: We recommend setting the motor acceleration and deceleration time to 0.4 seconds.

(400W)60mm Servo drive:

Position accuracy (mm)		0.04	
Ball screw lead (mm)		48	
Maximum speed (mm/s)		2000	
Maximum payload (kg)	Horizontal	15	
	Vertical	-	
Rated thrust (N)		85	

Note:

1. We recommend setting the motor acceleration and deceleration time to 0.2 seconds.



Size Details

1.U: Upper

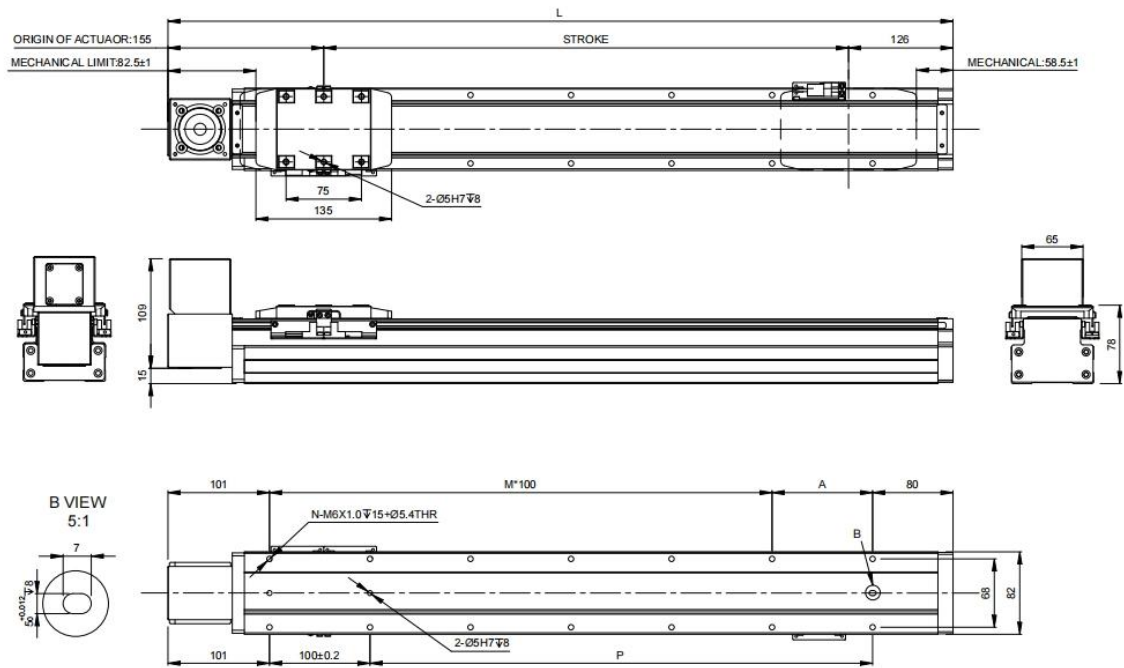

Stroke	50	100	150	200	250	300	350	400	450	500	550	600	650	700	750	800	850	900	950	1000	1050	1100	1150	1200	1250
L	331	381	431	481	531	581	631	681	731	781	831	881	931	981	1031	1081	1131	1181	1231	1281	1331	1381	1431	1481	1531
A	50	100	50	100	50	100	50	100	50	100	50	100	50	100	50	100	50	100	50	100	50	100	50	100	50
M	1	1	2	2	3	3	4	4	5	5	6	6	7	7	8	8	9	9	10	10	11	11	12	12	13
N	6	6	8	8	10	10	12	12	14	14	16	16	18	18	20	20	22	22	24	24	26	26	28	28	30
P	50	100	150	200	250	300	350	400	450	500	550	600	650	700	750	800	850	900	950	1000	1050	1100	1150	1200	1250
KG	3.15	3.42	3.69	3.97	4.25	4.52	4.80	5.07	5.35	5.63	5.90	6.17	6.44	6.71	6.98	7.25	7.52	7.79	8.06	8.33	8.60	8.87	9.14	9.41	9.68

Reference motor size:

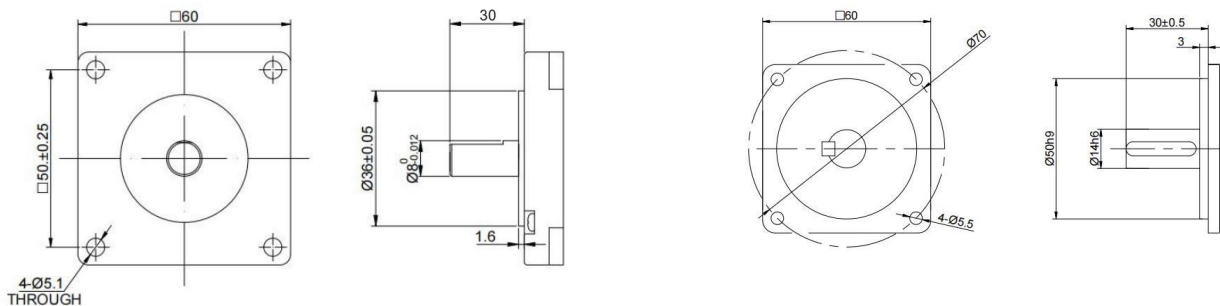

NEMA 24

(400W)60mm Servo

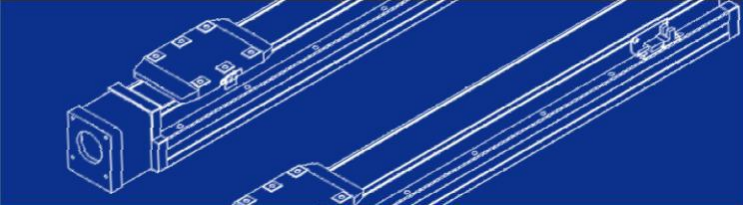

2.B: Under Fold

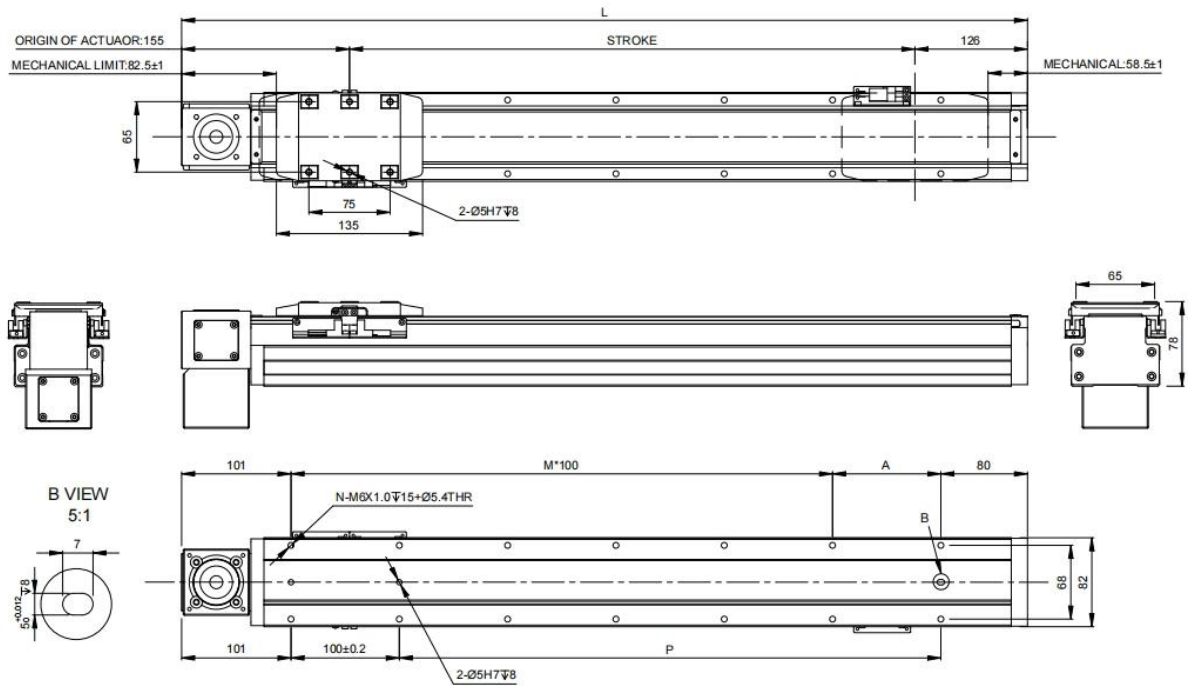

Stroke	50	100	150	200	250	300	350	400	450	500	550	600	650	700	750	800	850	900	950	1000	1050	1100	1150	1200	1250
L	331	381	431	481	531	581	631	681	731	781	831	881	931	981	1031	1081	1131	1181	1231	1281	1331	1381	1431	1481	1531
A	50	100	50	100	50	100	50	100	50	100	50	100	50	100	50	100	50	100	50	100	50	100	50	100	50
M	1	1	2	2	3	3	4	4	5	5	6	6	7	7	8	8	9	9	10	10	11	11	12	12	13
N	6	6	8	8	10	10	12	12	14	14	16	16	18	18	20	20	22	22	24	24	26	26	28	28	30
P	50	100	150	200	250	300	350	400	450	500	550	600	650	700	750	800	850	900	950	1000	1050	1100	1150	1200	1250
KG	3.15	3.42	3.69	3.97	4.25	4.52	4.80	5.07	5.35	5.63	5.90	6.17	6.44	6.71	6.98	7.25	7.52	7.79	8.06	8.33	8.60	8.87	9.14	9.41	9.68

Reference motor size:

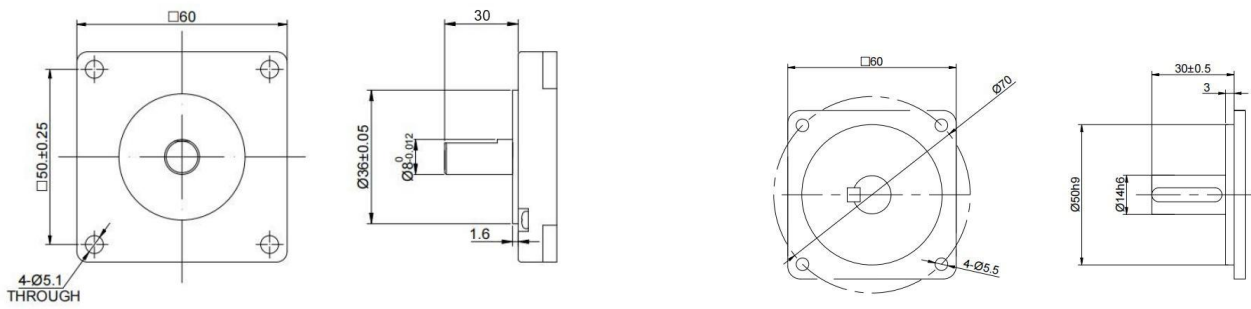

NEMA 24

(400W) 60mm Servo

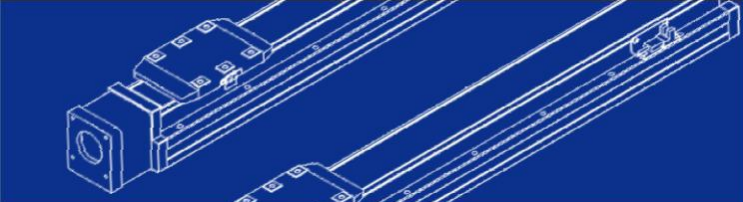

3.L: Left Fold

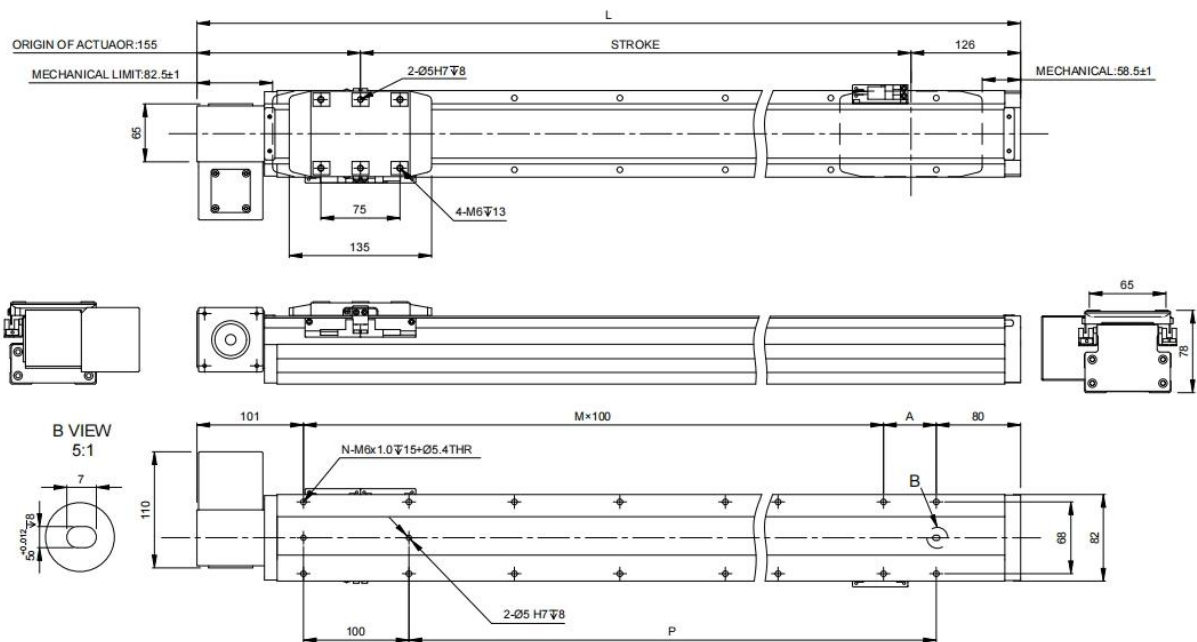

Stroke	50	100	150	200	250	300	350	400	450	500	550	600	650	700	750	800	850	900	950	1000	1050	1100	1150	1200	1250
L	331	381	431	481	531	581	631	681	731	781	831	881	931	981	1031	1081	1131	1181	1231	1281	1331	1381	1431	1481	1531
A	50	100	50	100	50	100	50	100	50	100	50	100	50	100	50	100	50	100	50	100	50	100	50	100	50
M	1	1	2	2	3	3	4	4	5	5	6	6	7	7	8	8	9	9	10	10	11	11	12	12	13
N	6	6	8	8	10	10	12	12	14	14	16	16	18	18	20	20	22	22	24	24	26	26	28	28	30
P	50	100	150	200	250	300	350	400	450	500	550	600	650	700	750	800	850	900	950	1000	1050	1100	1150	1200	1250
KG	3.15	3.42	3.69	3.97	4.25	4.52	4.80	5.07	5.35	5.63	5.90	6.17	6.44	6.71	6.98	7.25	7.52	7.79	8.06	8.33	8.60	8.87	9.14	9.41	9.68

Reference motor size:

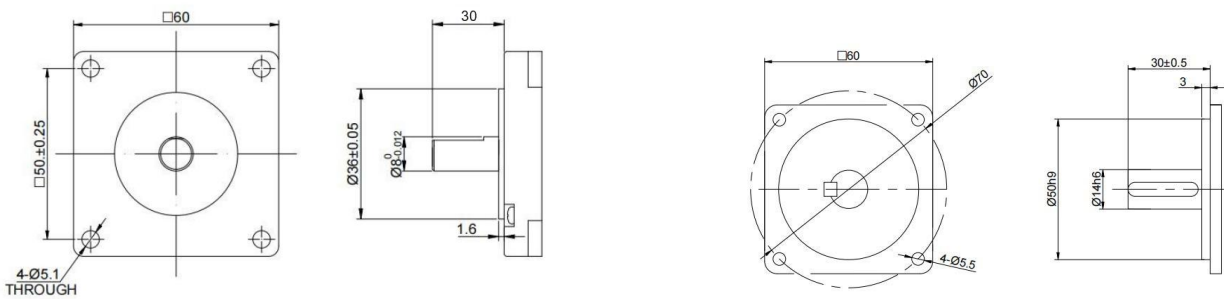

NEMA 24

(400W)60mm Servo

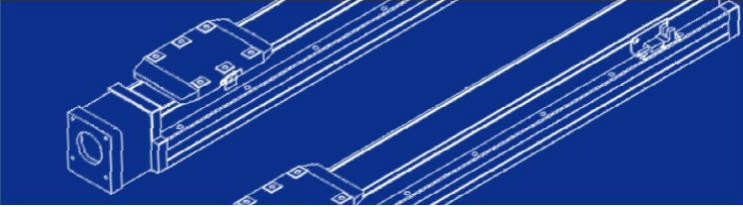

4. R: Right Fold

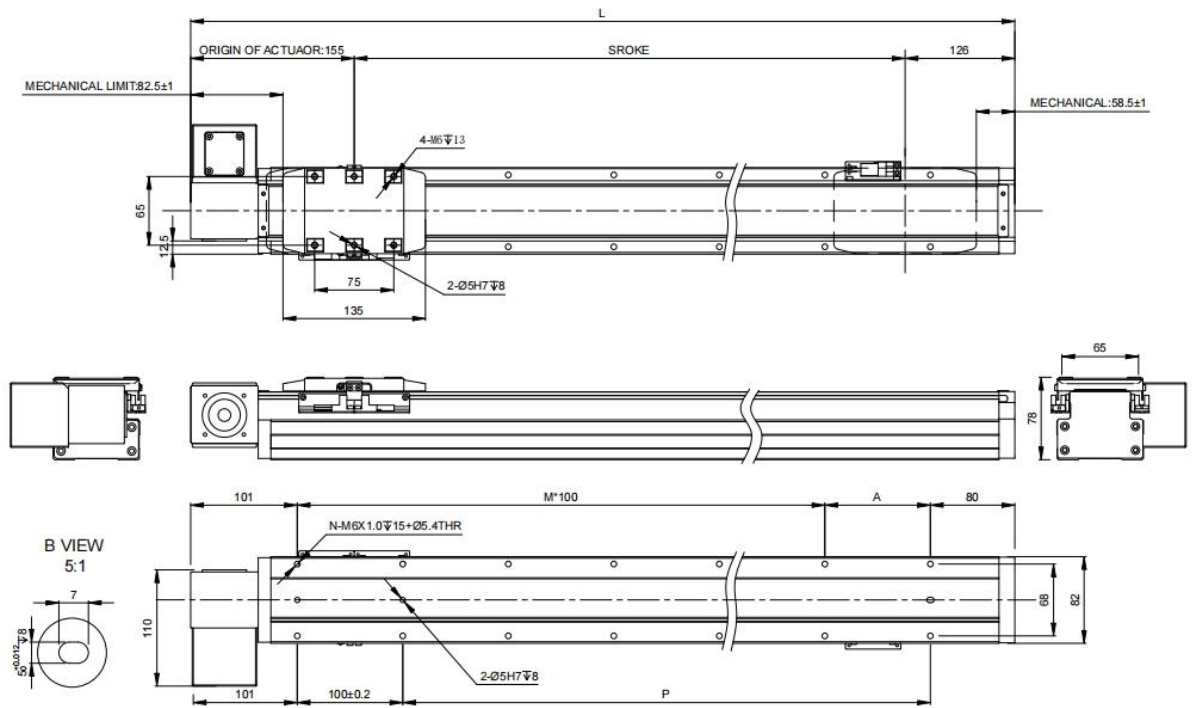

Stroke	50	100	150	200	250	300	350	400	450	500	550	600	650	700	750	800	850	900	950	1000	1050	1100	1150	1200	1250
L	331	381	431	481	531	581	631	681	731	781	831	881	931	981	1031	1081	1131	1181	1231	1281	1331	1381	1431	1481	1531
A	50	100	50	100	50	100	50	100	50	100	50	100	50	100	50	100	50	100	50	100	50	100	50	100	50
M	1	1	2	2	3	3	4	4	5	5	6	6	7	7	8	8	9	9	10	10	11	11	12	12	13
N	6	6	8	8	10	10	12	12	14	14	16	16	18	18	20	20	22	22	24	24	26	26	28	28	30
P	50	100	150	200	250	300	350	400	450	500	550	600	650	700	750	800	850	900	950	1000	1050	1100	1150	1200	1250
KG	3.15	3.42	3.69	3.97	4.25	4.52	4.80	5.07	5.35	5.63	5.90	6.17	6.44	6.71	6.98	7.25	7.52	7.79	8.06	8.33	8.60	8.87	9.14	9.41	9.68

Reference motor size:

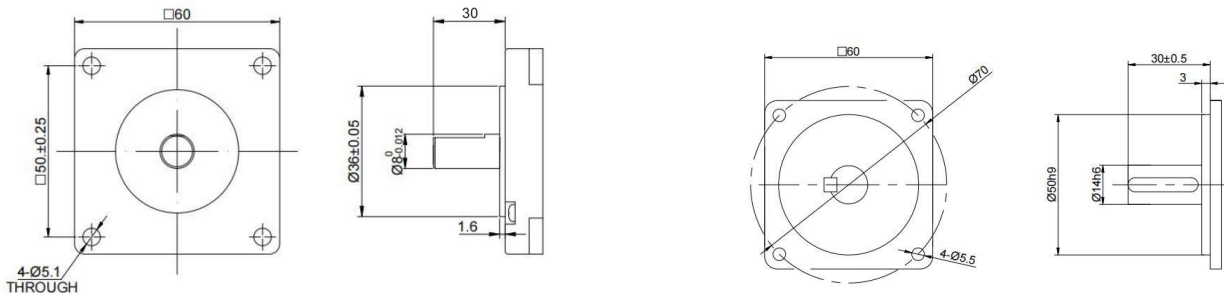

NEMA 24

(400W)60mm Servo

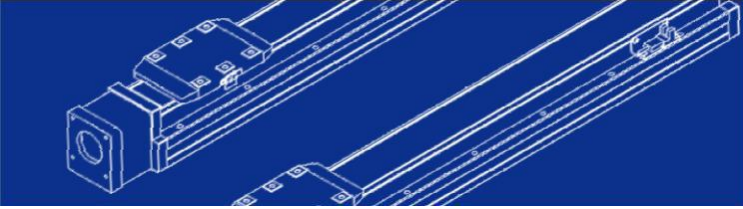

Sensor Wiring

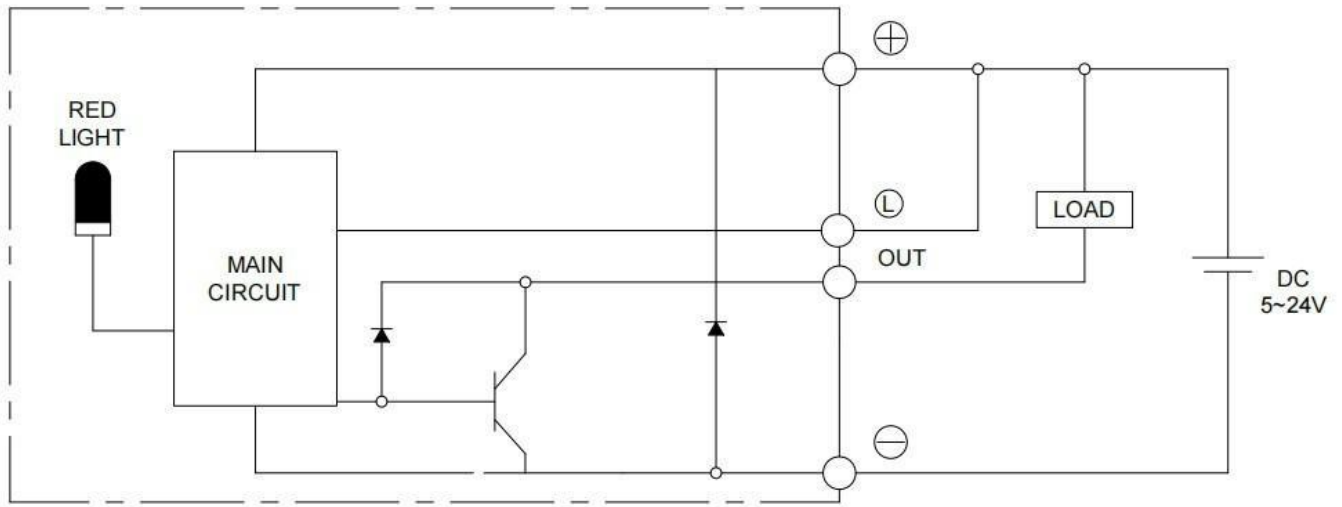

Horizontal installation

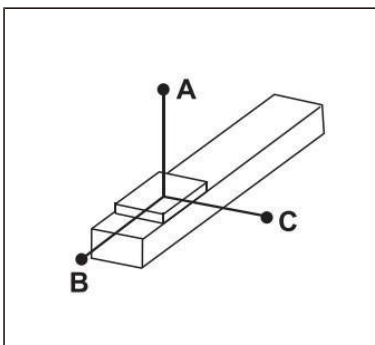

		A	B	C
Lead 48	5KG	850	322	395
	10KG	560	185	226
	15KG	473	135	156

Wall installation

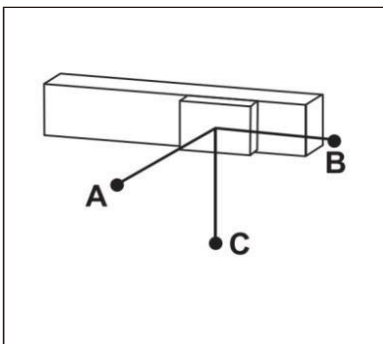

		A	B	C
Lead 5	5KG	355	310	532
	10KG	210	196	455
	15KG	171	155	435

(Unit: mm)

The torque value in the chart indicate the center of gravity;

Operation life is 10,000km when the product is using under the specified conditions.